

## INSTALLATION INSTRUCTIONS

240RAII-11/02

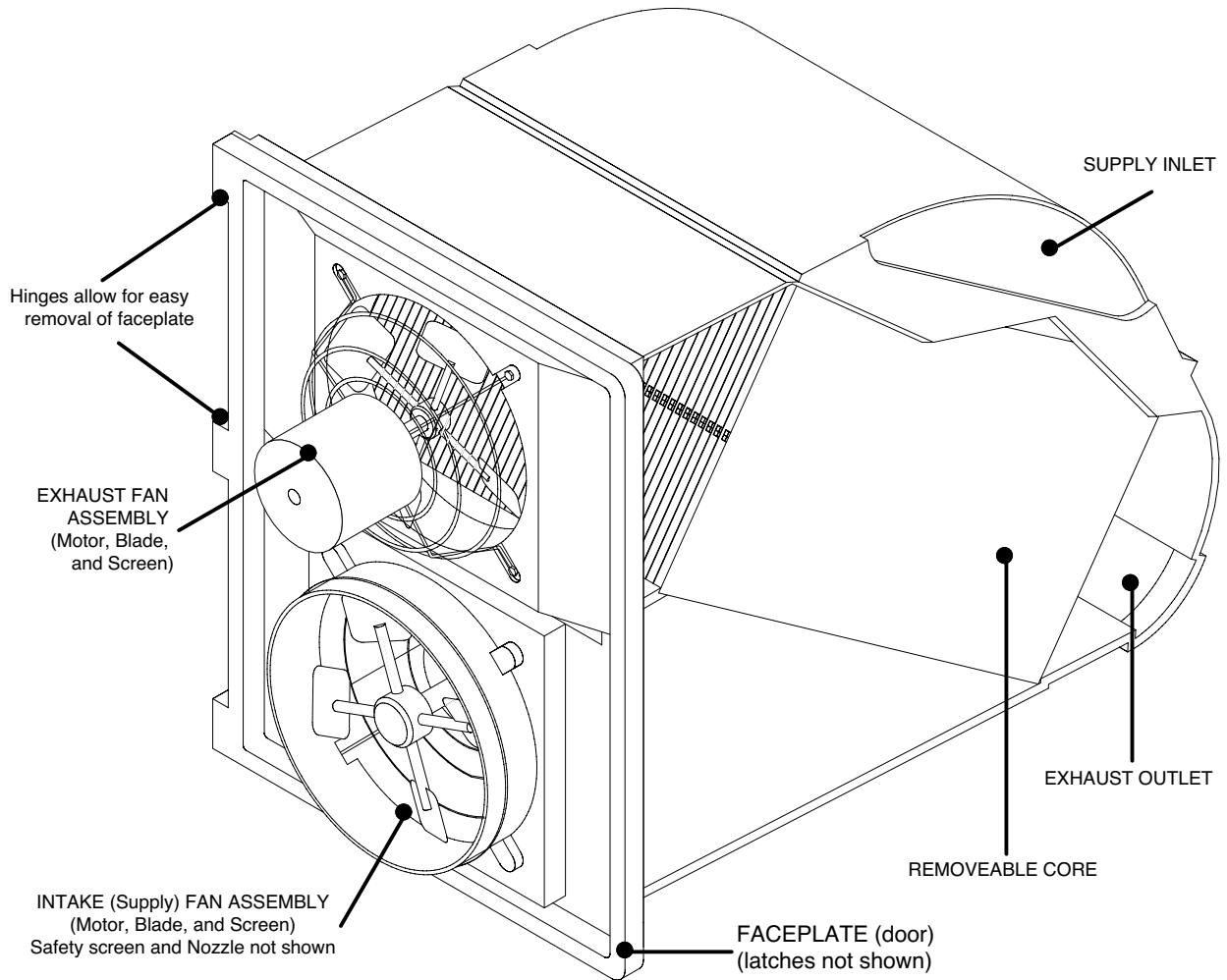

Part #	Description
000300	On/Off Switch
000310	608 Bearing (RA400)
-	-
000720	Switch Boot
003550	Fan Blade (RA400)
-	-
003620	4 MFD Capacitor (RA402)
-	-
415709	MK402 Motor Kit (Motor, Capacitor, Hdwr)
-	-
415810	SSAC Recycle Timer

Part #	Description
415510	Wash Nozzle Kit
750300	Autowash Module & Solenoid
750210	Autowash Remote Programmable Timer
415620	Model 100 Manual Variable Speed Control

This is only a partial listing of the most common parts only. Many other components are available from your DEL-AIR Dealer

## CHOOSING THE LOCATION:

If you have not done so, contact your dealer or DEL-AIR for a FREE ventilation Design. Alternatively, the following guidelines should give satisfactory performance.

1. Keep in mind that a heat recovery ventilator (HRV) serves as both EXHAUST and FRESH AIR INTAKE. Unlike a direct fresh air inlet though, the air is pre-warmed by waste heat in the outgoing air. One or more HRV's can often provide 100% of the cold weather heating and ventilation needs. It must work in conjunction with other fans and inlets during warmer weather.
2. Mount the HRV on the same side and preferably at least 10 ft. (3m) from winter exhaust fans. A South facing wall is best.
3. The RA-Series heat exchanger is setup from the factory to drain all wash water and condensate outside your building. Ensure that the area around the heat exchanger outside is clear of anything which could be damaged by the drainage. Consult your DEL-AIR dealer if inside drainage is preferred.
4. Provide a 200-240VAC voltage supply and a water supply line within 3 ft. (0.3m) of the unit's location.
5. A fresh air diffuser is supplied with every RA series HRV. It may be used to distribute the supply air across rooms up to 25' each side without duct work. For wider rooms, or to work into a special ventilation design, duct work may be attached directly to the fresh air discharge. Round and square adapters are available through your Del-Air dealer. Remember that the FRESH AIR FAN REVERSES DURING DEFROST! Air bags will collapse during defrost, restricting air flow. See your dealer for special instructions for using poly distribution bags.

## INSTALLATION

1. Mark the rough opening according to the dimensions in TABLE 1.
2. Cut and remove the interior sheathing with a jig saw, circular saw, reciprocating saw or router.
3. Carefully cut and remove the insulation.
4. Drill out the corners of the opening to mark the exterior sheathing. From Outside, cut the exterior sheathing or metal away.
5. If desired, block the rough opening with lumber toenailed in place and J-trim the outside metal.

**Table 1** Rough Opening Dimensions

Model	Width	Height
RA402	14-1/2"	22-1/2"
-	-	-

6. Open the door of the DEL-AIR RA-series HRV, and slide the core out. This makes it lighter and easier to handle. Reclose the door.
7. Slide the exterior shell into the rough opening, making sure it fits squarely and seats along the entire flange. Attach with the four screws provided.
8. Caulk around the mounting flange with a construction grade sealant.
9. Insert the core into the exterior shell. Gently push or tap the core to ensure it is firmly seated on all four corners.
10. Close the door. Check to make sure the door seals against the core properly to minimise cross contamination. Hold the door closed using the latches supplied.
11. Attach the supply air diffuser with the screws provided, or connect round or square ducting.
12. Connect the wash nozzle line to the water supply. A ball valve may be used to turn the water on and off, or use the DEL-AIR Autowash Timer and Solenoid for automatic cleaning. Order part number 750210 (one per facility) and 750300 (one per unit).

## OPERATION

1. Plug the unit into a 200-240 VAC outlet or wire direct using diagrams on opposite page.
2. Fan Speed - The RA-series may be wired to any type of thermostat or variable speed controller, to provide adjustment of the ventilation rate. Follow the wiring diagrams supplied with your DEL-AIR Control or consult your dealer for other instructions.
3. Auto Defrost - The HRV control automatically defrosts the core for 8 minutes every hour. The supply fan reverses, driving warm barn air through the core to melt out any ice. After 8 minutes, it returns to normal. It will not defrost more than once per hour, ensuring a continuous supply of fresh air. *Leave the Defrost switch in the ON position at all times.* Turning it off stops the defrost timer.
4. Cleaning - Spray the core with clean water daily! Regular flushing of core prevents dirt build-up, and ensures maximum performance at all times. Once or twice a season, remove the core and thoroughly clean it with a pressure washer, or with the DEL-AIR Wash Wand. The optional automatic timer and Solenoid can wash the core twice daily for one minute. This has proven to be highly effective.
5. With regular maintenance, you can expect the performance of your HRV to be as shown in Table 2 on the opposite page.

## SERVICING

1. Twice a year, remove and inspect the core. Clean with soapy water.
2. Rotate the fan motors by hand. If they seem rough, replace the bearings.

The wiring diagrams shown on the right in Figure 1 is provided for your reference. All RA-Series heat exchangers come pre-wired and will run full speed only.

The RA Series heat exchangers may be connected to any variable speed control (either manual or automatic). Consult your DEL-AIR Dealer for instructions on how to connect your speed control to the heat exchanger.

Replacement parts for the RA-Series electrical components are listed in the tables on the front page as are some options for automatic wash and speed controls available from DEL-AIR.

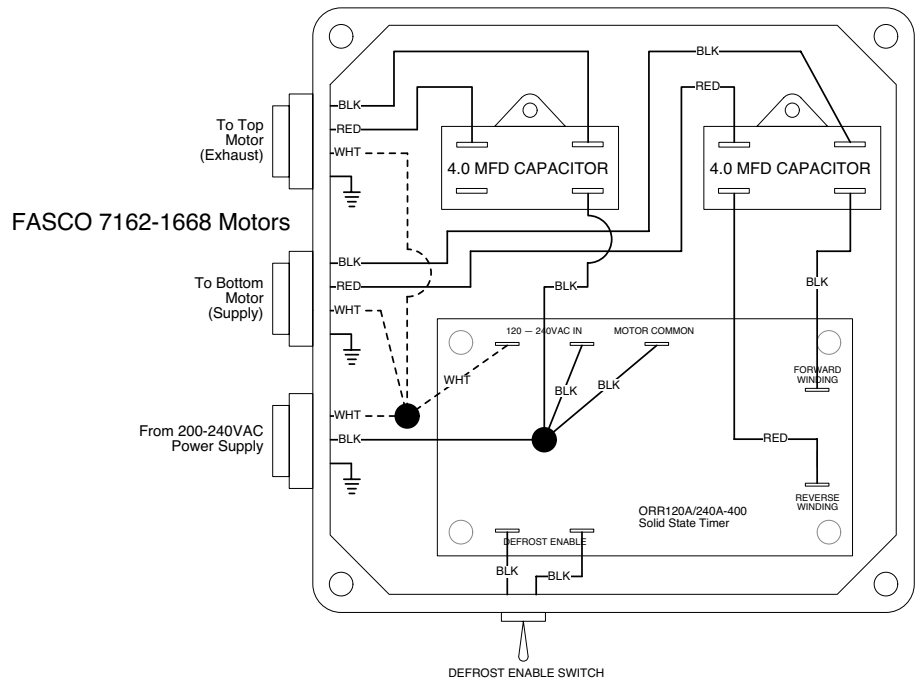

**Figure 1** RA402 Wiring Diagram as of November, 2002

**Table 2** 240V RA-Series Performance Data

	Airflow (cfm)		PAMI Test Performance (Indoor 70° F, Outdoor - 30° F)		Power Requirements (120V / 60Hz)	
	Supply	Exhaust	Heat Recovered (BTU/Hr)	Efficiency % (HRR)	Amps	Watts
<b>RA402</b>	298	385	17300	41	1.2	240
-	-	-	-	-	-	-

## LIMITED WARRANTY

DEL-AIR SYSTEMS LTD. offers an additional "System Performance Guarantee™" to purchasers who take advantage of the free ventilation planning service. Contact your dealer for details, or call a Del-Air Sales Representative.

DEL-AIR SYSTEMS LTD. warrants to the purchaser the full repair or replacement value of any part proven to be defective in material or workmanship, for one year from date of original purchase.

### OTHER EXTENDED WARRANTIES:

MOTORS - 1 year.

PLASTIC HOUSINGS - 10 year full value.

HRV CORES - 10 years full value.

## TERMS AND CONDITIONS

1. The owner is obligated to exercise due care and attention in the installation and use of this product.
2. This warranty is applicable only to DEL-AIR ventilation systems installed for agricultural confinement livestock operations.
3. Parts replaced or repaired under this warranty are warranted through the remainder of the original warranty.
4. This warranty does not cover cost of shipping defective or repaired or replaced parts to or from original customer.
5. DEL-AIR Systems Ltd. reserves the right to make changes and improvements to its products at any time with the express understanding that such changes and improvements do not impose any obligation to install such changes and improvements on products previously sold.

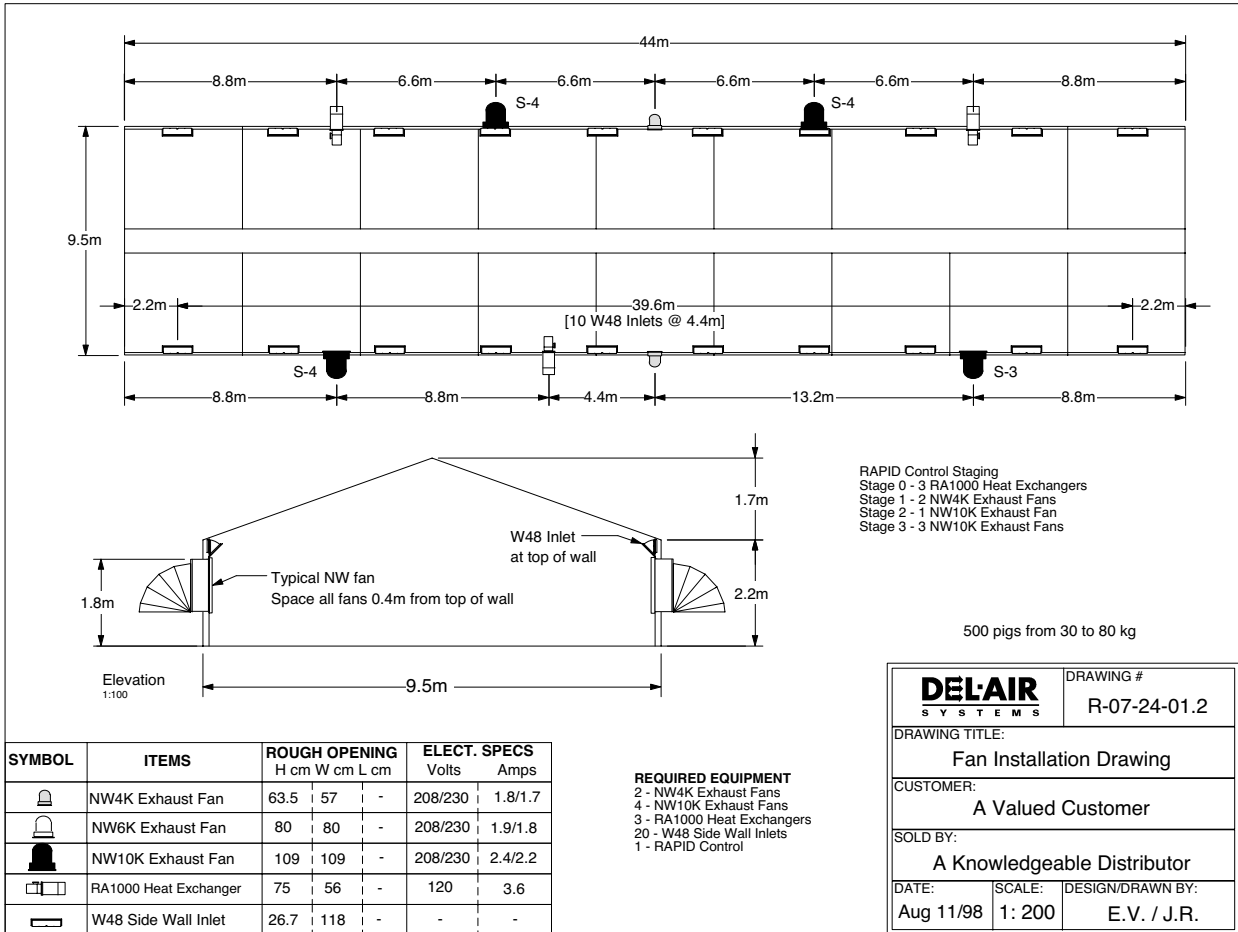

Figure 2 Sample Ventilation Plan

This Product was Quality Assured by:

**DEL-AIR SYSTEMS LTD / DEL-AIR Americas Ltd..**

P.O. Box 2500  
 1704 - 4th Avenue  
 Humboldt, SK S0K 2A0  
 Phone: (306) 682-5011  
 Toll Free: 1-800-667-0737  
 Fax: (306) 682-5559